



**October • 2014**

**Issue 8  
38th Year**

**Delivered Door-to-Door by Park  
Residents FREE Every Month**

**Monthly Mania Winner!  
\$100 • James Wright  
Appliance Specialty**



**Walter & Joan Martin of Americana Cove  
Are Busy Clowning Around**

**view this newsletter on-line at [www.monthly-media.com](http://www.monthly-media.com)**



**FOR AD RATES & INFO 727-484-7488 • info@monthly-media.com**

**Briar Creek Officers & Committees**

**Directors**

**Phase I**

**Phase II**

President.....	Jim McBride (791-3889).....	Billie Ann Berry (797-3116)
Vice President .....	Joe Daley (799-4467) .....	Billie Ogradowski (470-9118)
Secretary .....	Ray Farrell (799-7004).....	Billie Ogradowski (470-9118)
Treasurer.....	Bob Barr (644-8136) .....	Joan Davis (726-4829)
Director .....		Bill Briggs (726-1915)
Director .....		Bob Bowlby (724-9406)
Director .....		Arnold Grohskopf (533-6603)
Director .....		Bill Russo (406-980-0838)

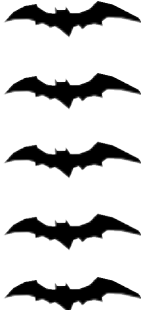

- Roads/Grounds/Utilities  
Bob Barr (644-8136)
- Clubhouse & Clbhse Bookings:  
Joe Daley (799-4467)
- Pool Recreation Area  
Dottie Hertel (726-4428)
- Lawns & Trees  
Barbara Pestic (726-4174)
- Beautification Chairperson:  
Barbara Pestic (726-4174)
- Amendments:  
Gene Arend (725-5844)
- Sales/Lease-Inspections  
Linda Miller (799-2623)

- Alterations/Renovations/Lawns  
Billie Ann Berry (797-3116)
- Clubhouse/Pool/Recreational Areas  
Bob Bowlby (724-9406)
- FOBS/Home Inspections  
Joan Davis (726-4829)
- Grounds/RV Area/Lakes  
Bill Briggs (726-1915)
- Roads/Utilities/Garage Bldg.  
Bill Russo (406-980-0838)
- Home Sales and Rentals  
Billie Ogradowski (470-9118)
- Lower Water Bill Committee  
Bill Beyer, Bob Bowlby, Roger Kolvek,  
Joe Donato, Dick Little,  
Paul Spencer, Arn Grohskopf

**Social Club Officers**

President.....	Ann Daley (799-4467).....	Sandy Fassett (424-6045)
Pres. Elect .....	Dave Doran (585-329-3827) .....	Sandy Watson (286-6812)
Vice President .....	Elsie Anderson (474-5653).....	Robin Feeley (796-5879)
Recording Secy. ....	Pauline Hoad (723-9710) .....	Brenda Greene (725-4066)
Corr. Secy.....	Pat Bourdon (797-3252).....	Arlene Lambert (724-6482)
Treasurer .....	Gene Arend (725-5844).....	Pete Loranger (421-2321)
Asst. Treasurer .....	JoAnn Barr (669-3820)	
Auditor .....	JoAnn Barr (669-3820).....	Audrey O'Connor (723-2148)
Past President.....	Betty Chatigny (216-3871).....	Dottie Frederich (725-4221)
Parliamentarian .....	Gene Arend (725-5844).....	Arn Grohskopf (533-6603)
Amendments .....	Gene Arend (725-5844).....	Marsha Bowlby (724-9406)
Clubhouse Phone .....	796-3033 .....	669-0119

**Board of Directors Responsibilities ... Social Club Committee Chairpersons**

Aquacise.....	Terry Gregory .....	TBA
Amendments .....		Marsha Bowlby (724-9406)
All Media Art .....	Jack Dennis (207-739-0370)	
Bazaar .....	Dave Doran (585-329-3827) .....	Pete Loranger (421-2321)
Bereavement .....	Joan O'Dell (796-4076) .....	Barbara Bergling (799-2904)
Bingo.....	Jean Richter (725-3701) .....	Pete Loranger (421-2321)
Bird Rescues .....		Barbara Walker (798-2385)
		Lynn Zablo (813-310-9363)
Birthdays/Anniversaries.....	Betty Chatigny (216-3871).....	Pete Loranger (421-2321)
Blood Bank .....		Don Meek (712-2526)
Blood Pressure Tests .....	Mariecia Maschak (799-3603) .....	Darlene Beyer (725-9644)



# MODERN AIR CONDITIONING



& HOME SERVICES, Inc.

Expires 10/31/14  
**Special!** 

**\$39<sup>00</sup>**  
**A/C & Heat Inspection or Service Diagnostic**

Coupon required at time of service during regular business hours & cannot be combined with other offers.

- HONEST and FAIR - SAME DAY SERVICE
- FREE Estimates on A/C Installations

**27 ★ 541-5541 15**

[www.modernac.com](http://www.modernac.com)

ALL BRANDS • Since 1976 • CACO 21320

# ROOF OVERS Summer Rains Are Here?

**SAVE 10% NOW!** 

10/1/14 Thru 10/15/14

"Our Owner Has Been Serving Pinellas County Since 1980."

**NO Sub-Contractors**  
**"Ask Your Neighbors About Us."**

Lic #: C-2387

**24 ★ ASC 547-8300 21**

## ASC

Lic #C-2387

ALUMINUM SPECIALTY CONTRACTORS, INC.  
 "A No-Nonsense Company"

# WINDOWS



**FREE Installation!**

(minimum 6 windows)  
 10/1/14 Thru 10/15/14



**24** 

**547-8300**

 **21**

DUNEDIN • CLEARWATER • COUNTRYSIDE

## ACTION

Licensed & Insured

## APPLIANCE SALES & SERVICE

SINCE 1973

REFRIGERATOR & MAJOR APPLIANCE SERVICE

GENERAL ELECTRIC • HOTPOINT • SEARS  
 • WHIRLPOOL • TAPPAN • FRIGIDAIRE

- ★ EMERGENCY REFRIGERATOR SERVICE
  - ★ FREE Service Call with Repairs
- Service & Parts For All Major Brands

**10% DISCOUNT WITH REPAIRS WITH THIS AD**



- REFRIGERATORS • FREEZERS • WASHERS
- DRYERS • RANGES • DISHWASHERS
- DISPOSALS • WATER HEATERS



FREE DELIVERY on Parts For The Do-It-Yourselfer

**21 ★ 736-1106 or 786-7076 21**

**SAFETY HARBOR • PALM HARBOR**

# VINYL SIDING

**Why Paint? Vinyl is FINAL!**

**Give Your Home a Makeover!**

**TRULY Family Owned & Operated**

Visit Our Showroom Display  
 7420 Park Blvd. • Pinellas Park

**ASC** Lic # C-2387 **547-8300**  
 visit: [www.ascaluminum.com](http://www.ascaluminum.com) ★

# CENTURY AWNINGS

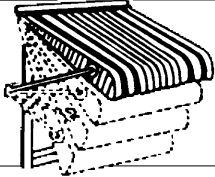

- Fabric & Aluminum AWNINGS
- MINI BLINDS
- Free Estimates • Licensed & Insured

**10% OFF**  
to Park Residents

- ALL WEATHER CURTAINS
- VERTICAL BLINDS



**559-8811** <sup>52</sup> ★ QUALITY PRODUCTS LOCALLY MADE - SINCE 1959 <sup>34</sup>  
13170-A 90th Street N., Largo • Previously Located on Starkey Road





[WWW.CAPITALGOLFCART.COM](http://WWW.CAPITALGOLFCART.COM)

Pinellas County's  
Authorized



Dealer

## CARTS

**Easy Financing**  
— as low as —  
**\$59**  
per month

 <b>2011 EZGO RXV</b> \$2,995 <sup>00</sup> <small>Rebuilt 2 Year 1 Year Warranty</small>	 <b>2011 EZGO RXV</b> \$3,695 <sup>00</sup> <small>Completely Rebuilt, 2 Year or 10000 Miles 1 Year Warranty</small>	 <b>2012 EZGO RXV</b> \$4,295 <sup>00</sup> <small>Completely Rebuilt, 2 Year or 10000 Miles 1 Year Warranty</small>	 <b>CUSTOM 3" LIFTED CART</b> \$5,995 <sup>00</sup> <small>Reconditioned, New Body, F.E. Wheels 1 Year Warranty</small>
---	--	--	--

## BATTERIES / ACCESSORIES

Endurance 6V <b>\$79<sup>95</sup></b> <b>ENDURANCE</b> <small>24 Month Warranty With cover, carry out only.</small>	Endurance 8V <b>\$99<sup>95</sup></b> <b>ENDURANCE</b> <small>24 Month Warranty With cover, carry out only.</small>	Endurance 12V <b>\$139<sup>95</sup></b> <b>ENDURANCE</b> <small>24 Month Warranty With cover, carry out only.</small>	 <b>Exclusive 2 YEAR Battery Warranty</b> <small>See Store for Details</small>	 <b>Tire &amp; Rim \$36<sup>95</sup></b>
--	--	--	--	---

<b>Palm Harbor</b>	<b>Largo</b>
1015 Illinois Avenue	11788 66th Street North

# 727-772-8833

**1** Come Visit Our Showrooms! **1** ★

Monday thru Friday 9:00am-5:00pm      Saturday 9:00am-3:00pm



## Briar Creek Phase I News

Betty Chatigny, Editor 727-216-3871  
(email: [media@mybriarcreek.com](mailto:media@mybriarcreek.com))

---

The Monthly Media is available over the Internet, through our web pages, at [www.mybriarcreek.com](http://www.mybriarcreek.com). Please submit information for publication by e-mail. If you do not have a computer, you can drop your item(s) off at 30 Fox Trail Court.



### Important Phone Numbers

Briar Creek emergency information - (727) 726-7651  
Life-threatening emergency - 911  
Sheriff's Office non-emergency - (727) 582-6200  
Sheriff's Office – to check your house while you're out of town - (727) 582-6177  
Progressive Management - (727) 773-9542

### Monthly Media - Reminder

Help Keep Our Monthly Media!

When a company pays to advertise in our media, they want to see a return on their investment. To show how often our residents use their services, the company provides a "voucher" to each customer. These vouchers, when completed with your name and address, are collected and mailed to Monthly Media on the 10th of every month. The collection box is in the clubhouse and is located to the left of the front door. Every month there are drawings, with prizes anywhere from \$10 to \$100. If you are the lucky recipient of a prize, your name, as well as the name of the company whose services/products you used, will be published in the next issue.

Let's do our part. When you hire a company who advertises in the Monthly Media, be sure to ask for a voucher and/or coupon. If they don't supply one, use a calling card sized paper and have the service person sign it. Include both the name of the company, along with your name and address, and put it in the Monthly Media box in the clubhouse.



**A Complete Listing of Resident Services  
can be found on the page before your calendar**



# BOARD BUSINESS

## **Lawn Mowing - Barbara Pesic**

TREE TRIMMING; Trees grow rapidly during the summer months, and now some of the trees in the park have branches hanging too close to the roads. A fifteen foot (15') clearance is recommended between the road and tree branches to provide clearance for trucks entering the park. Trees also need trimming if they are blocking the illumination of our street lights. Please inspect trees and arrange for trimming so that we can keep our roads safe.



### **MOWING DATES**

October 10  
October 24

## **Board Agenda – Minutes**

The Agenda and Minutes for all Board of Director meetings are posted on the Directors section of the Bulletin Board in the clubhouse. Subsequently these will also be posted on the [www.mybriarcreek.com](http://www.mybriarcreek.com) website on the tab marked “Board of Directors”. It is appreciated if you review these on the bulletin board. If you wish to have a copy, please go to the web site and print the copy from there. If you do not have Internet access, then please ask a neighbor to access and print a copy for you. PLEASE DO NOT REMOVE these from the bulletin board.

## **TO: ALL BRIAR CREEK PHASE 1 PROPERTY OWNERS** **PROXIES FOR ANNUAL MEETING – DECEMBER 1, 2014 - IMPORTANT!**

You will be receiving your General/Limited Proxy in the mail from Progressive Management. It is important that all owners submit their Proxy for our Annual Meeting scheduled for 10:00 AM, Monday, December 1, 2014. Your completed Proxy ensures the Board of Directors will be allowed to conduct business during 2015.

Be sure you vote for each issue as explained in the Proxy. A quorum of owners (159 of 317) is required to pass the listed issues. Only one Proxy is valid per property. If you own two properties, submit a proxy for each one. Please show your Unit Number, then date and sign your Proxy before submitting. The signature must be any owner on the title. If you change, or have changed the title or mailing address since purchasing, you need to let Progressive Management know. You must submit your Proxy prior to 10:00 AM on December 1, 2014.

*....continued on page 9*

# REPLACEMENT WINDOWS

**"NO MORE DIRT"**

- Let Me Turn Your Screen Room into a Clean & Beautiful Sunroom • Glass Acrylic & Vinyl

**Complete Home Improvements**

[www.ChambersSpecialties.com](http://www.ChambersSpecialties.com) Since 1977

36 Aluminum C-2490 • Carpentry C-8898 **Rick Chambers** 5  
 ★ Chambers Specialties, Inc. **443-7222**

# HURRICANE ANCHORS LEVELING & BLOCKING

- Add Anchors • Carport Strapping
- Longitudinal Stabilizing
- Replace Rusted Anchors
- Retro-fit to Current State Standards



6 Insured • Bonded **727-330-7821**  
 State Lic. IH/102459/1  
 ★ **BBB** ACCREDITED BUSINESS  
**FLORIDA ANCHOR AND BARRIER COMPANY**

**Citrus Homes**  
**Meadowood Homes**  
 of Florida  
 "Building Dreams... One Home At A Time"  
 6030 Ulmerton Road • Clearwater • FL



"A Family Tradition Since 1959"



**Lot Model Clearance Sale**  
**SAVE THOUSANDS NOW!**

**WE DO IT ALL...**

- Removal • Replacement (1/3 mile east of U.S. 19)
- Carports • Garages
- Screened Rooms
- Landscapes & Much More!

**727-535-5262**



10 ★ Visit us Online at... [www.citrus-meadowood.com](http://www.citrus-meadowood.com) 7



Family Owned & Operated • Serving Florida Since 1977

**Weather-Lok**

# ROOF-OVER

**The Only Patented Lifetime Roof-Over You Will Ever Need!**

**100% Maintenance Free**



**Lowers Energy Costs Up to 30%**

**One Piece Blanket of Protection**

Licensed & Insured • CGC 1515749 • CCC 042787

**FREE** Evening & Weekend Appointments Available  
 Estimates **727-471-0820**

11 ★ [WWW.AMSOFFLA.com](http://WWW.AMSOFFLA.com) 11



Family Owned & Operated • Serving Florida Since 1977

**Replacement**

# WINDOWS

- Quality Workmanship • Fast Installations
- Competitively Priced

• **GLASS WINDOWS** Custom made windows with a unique combination of beauty, style & durability backed by our AMS warranty.

• **ACRYLIC ENCLOSURES** Your screen room alternative with acrylic panels, removable vents, sturdy aluminum frames & total screen room ventilation.

Licensed & Insured • CGC 1515749 • CCC 042787

Financing by Wells Fargo



**FREE** Evening & Weekend Appointments Available  
 Estimates **1-800-282-3572**

11 ★ [WWW.AMSOFFLA.com](http://WWW.AMSOFFLA.com) 11



Family Owned & Operated • Serving Florida Since 1977

**Trouble Free**

# VINYL SIDING

**Premium Insulated Siding**  
**• Fresh New Look • No More Painting**

- Enhance the Beauty and Value of Your Home
- Reduce Your Energy Costs
- Maintenance Free
- Large Array of Designer Styles & Colors
- Accent Your Home with All Types of Decorative Trim and Accessories.

Licensed & Insured • CGC 1515749 • CCC 042787

Financing by Wells Fargo



**FREE** Evening & Weekend Appointments Available  
 Estimates **727-471-0820**

11 ★ [WWW.AMSOFFLA.com](http://WWW.AMSOFFLA.com) 11

# DUNEDIN PLUMBING, INC.

Specializing in Manufactured Home Repairs

- Water Heater Repairs & Replacement • Complete Home Repipes
- Washer & Dryer Hookups • All Licensed Servicemen
- Family Owned & Operated Over 42 Years

483-Patricia Avenue • Dunedin

734-2879

State Lic. #RF0037427



42

27

## PAYLESS PAINTING SERVICES

Free Estimate C8369

727-470-5876

www.paylesspainting1.com



6

5

## HAVE YOU SUFFERED FROM WATER OR FLOOD DAMAGE?

Fully Guaranteed Property Repair Service & Floor Repairs



Call Us for a **FREE NO-PRESSURE No-Obligation Estimate**

727-288-4680

flatworksremodel@yahoo.com

• Licensed • Bonded • Insured

4 FlatWorks INCORPORATED CGC #1511054

Paid advertisement by FLUHS, Inc. d/b/a A&E Services

## ROOF OVER

Complete Mobile Home Service

by Mitchell Siding INCORPORATED

"Workmanship Makes the Difference"

Top Quality Work At Low Prices

• Licensed & Insured • Aluminum Contractor • PCCLB #C-7812

★ 25 586-6315



19

Everyone Sells Water Softeners...

**We Service Them!**

Factory Certified Technicians Servicing ALL Makes & Models of Water Treatment Including:

- Fleck • GE • Autotrol • Rainsoft • Culligan • Sears • Kenetico • Home Depot • General Ionics • Lowes



**FWT**  
FLORIDA WATER TREATMENT

Showroom located at 1398 Main Street, Dunedin

24 Hour Emergency Service! Free Estimates!

Family Owned & Operated Since 1951

Custom Built Water Treatment Solutions at Wholesale Prices

All Equipment Made In The USA

100% Financing Available for Qualified Customers

Rental Systems & Rent to Own Options Available

**NO SALT SYSTEMS AVAILABLE!**



26

www.flawatertreatment.com

727-736-2747

Custom built solutions!

Not the one size fits all approach of national brands!



## BUGGIN' OUT PEST CONTROL



Household Pest Control - \$35 every 2 mos.

- Inside, Outside & Underneath Termite Treatments
- Drywood & Subterranean Termite Treatments

11

★ Licensed • Insured

535-2629

11





There are several ways to submit your Proxy:

1. Drop in mail slot at Clubhouse Directors Office.
2. Give to Jo Ann Barr any time, or drop off at 106 Cedar Elm Dr put in black mail box at back door, or
3. Mail to Progressive Management.

It is recommended that your Proxy be dropped at the Directors Office or given to Jo Ann Barr. Mailing slows the tally process. Early submission ensures there are enough proxies received to conduct business during the 2015 year.

If you have any questions or need to know your Unit Number, please call Jo Ann Barr (727-669-3820). Thanks for your help.

PLEASE NOTE: Extra copies of the Proxy voting page will be available. Progressive Management will mail your Proxy to the address they have on record for you.

### **Disaster Management**

The Hurricane Disaster Planning Guide for Briar Creek has been updated. A copy can be printed from the [www.mybriarcreek.com](http://www.mybriarcreek.com) website. Click on the Disaster Tab and then open the Hurricane Pamphlet. Hurricane Season began on June 1st.



### **Welcome Back – Linda Miller & Pat Arend**

We want to welcome back all of our northern residents to Briar Creek and hope you had an enjoyable summer and some cooler weather. As fall is in the wind, it's time to check out your property for overgrowth of weeds or shrubs during our rapid growing season. Remember, a lot of us have hibiscus plants that need to be trimmed. These plants grow best when cut back to about three to four feet high or less. Anything over that and they will get leggy.

Our properties (most) are thirty plus years old and taking care of torn screens, or growth or debris on your roof will keep it in good condition. A few owners had to replace their roofs over the summer and the expense is quite hefty. So if you can avoid this by keeping the roof clear of debris to prevent damage, it could be a money-saver.

Our inspections will not begin until 2015; however, if you work on your property a little bit each month, it will keep looking pristine throughout the season. Remember, we're here to help you. If you have any questions, just call us. Looking forward to another successful inspection season.

### **Owner's Classified - Briar Creek Webmaster**

Do you have an item for sale or services available? The [www.mybriarcreek.com](http://www.mybriarcreek.com) website list products Briar Creek owners have for sale, as well as services they can provide. Also this page displays comments, satisfactory and unsatisfactory, on vendors they have hired. This is your ideal source on owner sales and services. If you have something to sell or information on a vendor, contact [webmaster@mybriarcreek.com](mailto:webmaster@mybriarcreek.com).



## SOCIAL ACTIVITIES

---

### Mark Your Calendars!! - Andy Philyaw

**S**unday, November 30, is Briar Creek's Hobby and Craft Show at Phase 1's Clubhouse. Both Phases are invited to participate! It's been many years since this event was held and there has been a lot of interest in having one, so here are the details:

Hours: 1PM-4PM

Cost: If you just want to display or demonstrate your hobby or craft, your table is FREE! If you would like to also sell your hobby or craft, each table is a nominal \$10.00 which goes to the Social Club. Money is not due until November 1.

You can have as many tables as you'd like.

Now is the time to show off all your hard work and talents and maybe make some money back on your investment of time and material! We have so-o-o many talented residents who have kept their talents to themselves. **NOW IS THE TIME TO SHARE!**

Contact Andy Philyaw, 793-9819, with any questions or to reserve your tables for this wonderful upcoming combined Phases event. Reminders will be published in the September, October and November Monthly Media and will be announced as a reminder by your Media Representative at both Phases' Coffee Hours periodically.

It will be a BLAST!



### Wednesday Meetings

Every Wednesday morning, there is a coffee meeting for all Phase 1 residents, (plus their visitors). Coffee and pastries are available to purchase at 8:30AM. The "official" meeting starts at 9:30AM.

During the meeting, visitors, as well as new residents, are introduced to the members in attendance. Also birthdays and anniversaries are announced, followed by an usually melodic serenade by the attendees. Our local maestro, Bob Thygerson, is our talented piano accompanist. Committee reports, important information, and upcoming social event dates are presented. A random drawing is held, pulling a name from a hopper which contains all the members of the Social Club. If a person's name is drawn, and they are wearing their name badge, they win \$5.00.

To join the Social Club, it's only \$1.00 per person (believe it or not, that dollar pays for an entire year). Please get in touch with our membership contact person, Pat Bourdon (797-3252) during the summer months, or Pauline Hoad (723-9710), for the remainder of the year. Either Pat or Pauline will make sure your name is included with the others in the hopper.

If you need a name badge, there is a sign-up sheet on the bulletin board. ID name badge costs are listed and it doesn't take long to get one in your hands. DeWayne Hehl, 724-1867, is

*...continued on page 12*

**INSIST on 8 ft. WIDE VAPOR BARRIER for a SEAMLESS FIT!**

# LOOKED

## UNDER YOUR MOBILE HOME LATELY?

**Insulation Under Your Home Falling Down?  
Holes and Tears in Your  
Vapor /Moisture Barrier?**



**FREE**  
**UNDER HOME INSPECTION**  
 Only with this COUPON



**Photographs  
Taken of  
Damaged Areas**



### **Insulation and Vapor Barrier Repairs**



- **Lifetime Vapor Barrier • Guaranteed for Life**
- Prevent Soft Floors • Keep Mold, Mildew, Rats, Snakes, Spiders, Ants, Roaches and Moisture OUT of Your House! • Lower Your Electric Bills

**FREE ESTIMATES**

Licensed by the  
State of Florida  
#IH/102549/1

**727-330-7821**  
Toll Free - 800-681-3772

**MILITARY  
& SENIOR  
DISCOUNTS**

**Family Owned  
& Operated**



- Insured • Bonded • Workman's Compensation Insurance
- Member: National Association of Mold Professionals

## **FLORIDA ANCHOR AND BARRIER COMPANY**

**6 ★ 11590 U.S. Highway 19 North • Clearwater • FL 33764**





the person who handles the name tags. If you have any questions, please give DeWayne a call.

If you would like to sponsor one of Phase 1's Wednesday coffee/doughnut hours to celebrate any special event in your life, whether an anniversary, birthday or in memory of a loved one, not only will you receive public accolades for your financial gift, you will also receive a personalized poster (picture included, if you wish) that will be displayed on Wednesday morning.

Please contact Joe Guizzerotti and/or Betty Chatigny for more details about coffee sponsorship.



**Phil Houpt**  
**(8/27/14 Winner)**



**George Schneider**  
**(9/3/14 Winner)**



**Bob Thygeron**  
**(9/10/14 winner)**

### **October Birthdays & Anniversaries - Betty Chatigny**

#### Birthdays

October	3	Kenneth Blake	October	14	John Pickering
October	3	Peggy Cummings	October	14	LuAnn Rathke
October	4	Jack Savage	October	16	Lesley Blake
October	5	Kirby Porter	October	16	Alice Tompas
October	5	Donna Rickard	October	17	Nancy Arguin
October	6	Charles Logue	October	20	Fanny Gurreri
October	7	Doris Jaeger	October	20	Joe Winder
October	7	Karen Ranieri	October	21	Margaret Beckerman
October	9	Diane Malek	October	21	Genelle Smith
October	9	Greta Vincent	October	23	Naomi Cline
October	13	Linda Hayes	October	23	Joan O'Dell
October	14	Ruth Kalbfleisch	October	23	Carol Ann Rice
			October	24	Ronald Payne



### Birthdays continued...

October	25	Nancy Costage
October	26	Robert Tompas
October	26	Barbara Trent
October	27	Michael Jordan
October	27	Carol Sisson
October	28	Marilyn Hegerty
October	29	Walter Kingsbury
October	29	Rad Pesic
October	31	Eugene Steffen

### October Birthdays & Anniversaries - Betty Chatigny

#### Anniversaries

October	2	Michael & Mary Jordan (1989)
October	10	Blaine & Gloria Hanna
October	11	Leon & Bernice Klamann
October	15	Ray & Evelyn Pillon
October	15	Tom & Mary Ann Horvath
October	26	Lloyd & Lois Harvey (1957)

*Note: Please notify Betty Chatigny if you would like your anniversary year included. If your birthday and/or anniversary information needs correction or inclusion, please notify Betty at 727-216-3871 (or email [bettychatigny@hotmail.com](mailto:bettychatigny@hotmail.com)).*

### Resident Directory Update

- Cary & Mabryan Hutchins, 42 Bear Run
- Leonard & Mary (Aleece) Montoya, 122 Beechwood



### Recent Deaths

#### August 2014

John Hull (husband of Claire Hull) former resident  
 Ray Farrell (husband of Sue Farrell), 52 Sugar Bear  
 George Rider, 84 Redwood



### Travel Club - Judy Young

Please see the bulletin board for all currently planned trips and sign up if you are interested. Plus, Judy announces all upcoming trips at the weekly Wednesday coffee meeting.

\*When signing up for trips, please contact Judy Young for payment information.

Suggestions for future trips are always welcome and your thoughts should be communicated to Judy Young (727-725-2090). Many more details are available for all of the above trips in the clubhouse, or sign up online [www.mybriarcreek.com](http://www.mybriarcreek.com) Travel.





# LEISURE ACTIVITY

Dave Doran

---

## Annual Bazaar

2014 Bazaar Update:

I am returning on October 21st and would like to schedule a quick meeting after coffee hour on the 29th (rather than the 19th) with the department heads. I still have not heard back from 50/50, Books, Furniture, Tools, Trash and Treasures. Also I am looking for a volunteer for the Liquor Raffle (not to taste test, of course). You can always send me an e-mail to let me know or call me on my cell: 585-329-3827. Looking forward to all those who will come from near or far to enjoy the Briar Creek Bazaar!

## JEWELRY—Helen Coar-Terry Henry

Terry and I are beginning to organize the items for our December bazaar. We will have more space this year to show off our “jewels.” We will begin pricing in October and continue through November. So please, if you have unwanted jewelry, purse, scarves, belts, you can give them to either Terry or Helen. Snowbirds, if you have room as you travel back, bring any of the above items with you and we all can help make this year’s bazaar a big success.

## Bingo - Jean Richter

Doors open at 5:15 p.m. and Bingo starts at 6:00 p.m. (note the time change). Joe and Jerry’s Café will start selling hot dogs, etc. on Tuesday, September 9, 2014 at 4:45 p.m. – 5:15 p.m.



## Exercise Classes - Low Impact Aerobics - Ray Pillon

The Low Impact Aerobics Sessions held on Tuesday, Thursday and Saturday mornings at 9:00 a.m. will be suspended for the summer months, and will resume in November with Ray Pillon's return.

## Krazy Kards Schedule 2014-15 - Earl & Nancy Ellis

November 16, 2014  
January 11, 2015  
February 15, 2015



### **Bridge Scores - Barbara Glasheen**

Bridge will resume in mid-October on Tuesdays at 1:00 p.m. at the clubhouse.

### **Shuffleboard - John Wilson**

The shuffleboard season is fast approaching. Our previous captains, Tom O'Dell and Gary Hoad, are handing the leadership to Ed Wahl, Gene Arend, and Bob Barr. The shuffleboard courts have been professionally reconditioned and are ready for a new season. Don Hall and Rad Pesic have been shuffling in the evening. Shuffleboard is a wonderful activity - friendly, skillful competition. October is a good starting time. We welcome all players, new and old.



### **Shuffling - Bob Barr**

Our courts were resurfaced this summer and we are looking for new players to join us for the upcoming season, that starts in November. All players with or without experience are welcome to come join us. We have two teams A and B. The A team, captained by Gene Arend and Bob Barr, plays on Wednesday afternoons and consists mostly of our experienced players. The B team, captained by Ed Wahl, plays on Monday afternoons and consists mostly of players who are less experienced. We have mixed practice sessions of A and B team players which will start around the first of October. We usually start gathering around 11:30 to 11:45 and practice till 1:00 or there about. Pointers, tips and strategy will be freely dispensed to new players. There is a variety of cue sticks in the shed behind the courts that anyone can use. Ed will most likely be returning sometime in October. Gene and I are around most of the year and can answer any questions you might have. It should be noted that practice time is not just limited to the above time but can be anytime you can get there. Our contact numbers are Ed (727) 797-5999, Gene (727) 725-5844, and Bob (727) 644-8136. It should be noted that this is a competitive, fun, challenging, and frustrating sport.

### **Attention Briar Belles who are also Phase II Briarettes:**

The speaker for the October 7th Tuesday 1:00PM meeting will be Nita Fields, Independent Designer of lockets. Every locket tells a story -- more importantly, the locket can tell YOUR story. You select what objects are placed in the locket; perhaps something precious and important to you, or that special item that might keep your loved one(s) close. Nita has a great fall collection. Please come join us. We will have dessert and coffee.

Carol Smitley, President, Briarettes





## COMPUTER HELP AT HOME

- Virus & Spyware Removal • Tune-Ups
- New Computer Set-Up • Wireless Routers
- Repairs/Upgrades • Training • Custom Builds
- Data Backup / Recovery / Destruction • Recycling
- Printers • Cameras • Advice • 36+ Years Experience

**Less than In-Store Prices 727-474-4285**

• Appointments 8 am - 9 pm • 7 Days per Week

**4** ★ [www.LargoTechServices.com](http://www.LargoTechServices.com) **4**

## Drywood Termite - Treatments - Without Tenting

- No Roof Damage
- No Move-Out
- No Odor

**10 Year Warranty**

**Other Services**

- Rodent Control
- Subterranean Termite Treatments
- Once-A-Year Pest Control



**NATURES RESOURCE PEST CONTROL, INC.**

**727-785-2552 FREE Estimates**  
State Lic. JB6861

**12** • Convenient • Family Owned **8**

- Serving Pinellas County Since 1993
- 2690 Woodhall Terrace, Palm Harbor

## Bob's

- Hand Wash & Wax
- No High Pressure Equipment

## MOBILE HOME WASHING

"Ask about our other services" **(727) 787-1459**

- All Work Guaranteed
- Licensed

**23** ★ **23** Servicing Pinellas & Pasco Counties

## PALM HARBOR & DUNEDIN ELECTRIC COMPANY INC.

### SPECIALIZING IN SERVICE

- ◆ 21 Years Experience
- ◆ Licensed & Insured
- ◆ Free Estimates



**24 HOUR EMERGENCY SERVICE**

**22** ★  State Lic. EC13002291  **22**

[www.dunedinelectric.com](http://www.dunedinelectric.com)

# 773-1622

## ARE YOU PAYING TOO MUCH FOR AUTO INSURANCE?

**Coverages:**

- Bodily Injury .....\$100,000 Each Pers./ \$300,000 Ea. Occur.
- Property Damage ....\$100,000 Each Occur.
- Uninsured Motorist ....\$100,000 Each Pers./ \$300,000 Ea. Occur.
- Pers. Injury Prot.....\$10,000 Ea. Person, Wage Loss Excluded
- Medical Payments.....\$5,000 Each Person
- Comprehensive .....ACV - \$500 Deductible
- Collision .....ACV - \$500 Deductible
- Road Trouble Serv. ....\$50 Each Occurrence
- Additional Exp.....\$30 Per Day / \$900 Each Occurrence

**Annual Paid In Full Premium..... \$884.99\***



Quote Details: -67 married male, vehicle driven for pleasure use, superior credit, 5 year clean driving record on all licensed household operators -2008 Chevy Impala LT, garaged in Pinellas County zip code 33771, equipped with Air-Bags, ABS and Anti-Theft device

\*NOTICE: Acceptability of all proposed applicants subject to underwriting approval, premium rates are subject to change. Rates will vary based on age of operator, driving record, credit history, garaging address and type of vehicle.

*O & Wilson Insurance Inc.*

**30** ★ **727-535-0524** **9**



# SERVICES DIRECTORY

## AIR CONDITIONING SALES/SERVICE

Barron's Air Conditioning.....	21
E & E Gliddon, Inc.....	back cover
Modern Air Conditioning Service Co., Inc.....	3

## APPLIANCE REPAIR

Action Appliance Sales & Service, Inc.....	3
Appliance Specialty, Inc.....	22
Bob's Appliance Repair.....	17

## AVON PRODUCTS

Avon Products.....	21
--------------------	----

## AWNINGS

Century Awnings Co.....	4
-------------------------	---

## BARBERSHOP

Andrew Ciresi Master Barber Shop.....	29
---------------------------------------	----

## CARPET CLEANING

Bill the Carpet Guy.....	21
Doll Brothers Carpet/Upholstery Clnrs.....	29

## CLEANING/INTERIOR

Doreen's Cleaning Service.....	29
--------------------------------	----

## COMPUTER SERVICES

Largo Tech Services, LLC.....	16
-------------------------------	----

## DENTIST

Dental Walk-In Clinic.....	25
----------------------------	----

## DRIVEWAY COATING

Concrete Wizard, Inc. (The Estimators).....	calendar
---	----------

## ELECTRICAL CONTRACTOR

Boss Electric Corp.....	calendar
Haseney Electrical Services, Inc.....	29
Palm Harbor and Dunedin Electric, Inc.....	16

## FLOOR REPAIR

Flatworks.....	8
Perfect Repair & Construction, Inc.....	25

## GOLF CARTS SALES & SERVICE

Capital Golf Carts, Inc.....	4
Recreational Golf Cars of Florida, Inc.....	29

## INSURANCE/AUTO

O. E. Wilson.....	16
-------------------	----

## KITCHEN CABINET REFACING

Swailes Re-Face It, LLC.....	25
------------------------------	----

## MANUFACTURED HOME SALES/NEW

Citrus Homes/Meadowood Homes.....	7
-----------------------------------	---

## MEDICAL DOCTOR

Vakesh Rajani, M.D.....	30
-------------------------	----

## MOBILE HOME SUPPLIES - RETAIL

Mobile Home Depot, Inc.....	21
-----------------------------	----

## MOBILE HOME WASH/WAX

Bob's Mobile Home Washing.....	16
Heller's Mobile Home Washing.....	back cover
Wyngarden Mobile Home Wash, LLC.....	22

## PAINTING/INSIDE & OUTSIDE

Payless Painting Services.....	8
--------------------------------	---

## PEST CONTROL

Buggin Out Termite & Pest Control, Inc.....	8
Nature's Resource Pest Control.....	16

## PHARMACY

Medicine Shoppe, The.....	22
---------------------------	----

## PLUMBING SERVICE

Dunedin Plumbing, Inc.....	8
Plumbing Patrol, Inc.....	26
Ray Duncan Plumbing, Inc.....	34

## REMODELING/INTERIOR

House Doctor.....	21
-------------------	----

## ROOF REPLACEMENT

AMS Advanced MH Systems.....	7
ASC Aluminum Specialty Contractors, Inc.....	3
Mitchell Siding, Inc.....	8

## ROOF WASHING

Heller's Mobile Home Washing.....	back cover
-----------------------------------	------------

## TIE DOWNS/MOBILE HOMES

Florida Anchor & Barrier Co.....	7
----------------------------------	---

## VAPOR BARRIER

Florida Anchor & Barrier Co.....	11
Florida Underhome Solutions.....	back cover
Superior Vapor Barrier, LLC.....	26

## VINYL SIDING

AMS Advanced MH Systems.....	7
ASC Aluminum Specialty Contractors, Inc.....	3
Mitchell Siding, Inc.....	31

## WATER SOFTENING

Florida Water Treatment, Inc.....	8
-----------------------------------	---

## WINDOW REPLACEMENT

AMS Advanced MH Systems.....	7
ASC Aluminum Specialty Contractors, Inc.....	3
Chambers Specialties, Inc.....	7

## *Bob's* APPLIANCE REPAIR

- Refrigerators
- Washers
- Dryers
- Ice Makers and more



**My PAPA Can Help You!**



5 ★ **637-4789** 5

# ⚡ Boss ELECTRIC

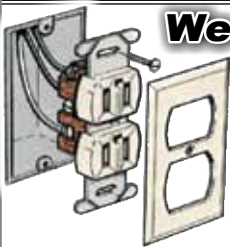

We Specialize in  
**MOBILE HOMES**

**EMERGENCY SERVICE AVAILABLE**

- Family Owned & Operated
- Digital TV Upgrade
- Surge Protection
- Ceiling Fan Wiring
- Panel Upgrade & Repair

**15% OFF LABOR**  
with this ad

**791-1308**

**FREE ESTIMATES**

Diagnosing & repairs will be charged accordingly.

**Senior & Military DISCOUNTS**

[www.bosselectriccorp.com](http://www.bosselectriccorp.com)



Lic. EC13005634  
Bonded & Insured **5**

**Make Your Ugly, Cracked  
DRIVEWAY  
Look Like New!**

**We Repair,  
Widen & Re-Surface**

**FREE ESTIMATES • 7 DAYS A WEEK**



**AARP**  
**\$200 DISCOUNT**

[www.ConcreteWizard.us](http://www.ConcreteWizard.us)



**789-5444** **5**

Lic. #C5528

**CONCRETE WIZARD**

# OCTOBER • 2014

Sunday	Monday	Tuesday
5	6 Sit & Stitch 1PM Bingo - Sell @ 5:15 Play @ 6PM	BOWL Mah Jo Briarett
12	13 Sit & Stitch 1PM Bingo - Sell @ 5:15 Play @ 6PM  <i>Columbus Day</i>	BOWL Mah Jo
19	20 Sit & Stitch 1PM Bingo - Sell @ 5:15 Play @ 6PM	BOWL Mah Jo Condo B 7PM
26 BREAKFAST	27 Sit & Stitch 1PM Bingo - Sell @ 5:15 Play @ 6PM	BOWL Mah Jo

## Briar Creek Phase II - Calendar



Tuesday	Wednesday	Thursday	Friday	Saturday																																																								
	1 Biker's Breakfast at "Daddy's"	2	3 Dominos 6PM	4 Coffee & Donuts 8AM Social Club News 9AM																																																								
7 ING ngg 1PM tes' 1PM	8 Biker's Breakfast at "Daddy's"	9	10 Dominos 6PM	11 Coffee & Donuts 8AM Social Club News 9AM																																																								
14 ING ngg 1PM	15 Biker's Breakfast at "Daddy's" Ladies Luncheon 1PM All Media Due before NOON	16 Monthly Mingle 4:30-6PM	17 Dominos 6PM	18 Coffee & Donuts 8AM Social Club News 9AM Non- Perishable Foods for Food Pantry Social Club Board Meeting 8:45AM OKTOBERFEST																																																								
21 ING ngg 1PM board Meeting	22 Biker's Breakfast at "Daddy's"	23 BUNCO	24 Dominos 6PM	25 Coffee & Donuts 8AM Social Club News 9AM																																																								
28 ING ngg 1PM	29 Biker's Breakfast at "Daddy's"	30	31 Dominos 6PM TRICK OR TREAT  <span style="color: red;">Halloween</span>	<p style="text-align: center;">NOVEMBER 2014</p> <table style="width: 100%; border-collapse: collapse;"> <tr> <td style="text-align: center;">S</td> <td style="text-align: center;">M</td> <td style="text-align: center;">T</td> <td style="text-align: center;">W</td> <td style="text-align: center;">T</td> <td style="text-align: center;">F</td> <td style="text-align: center;">S</td> </tr> <tr> <td></td> <td></td> <td></td> <td></td> <td></td> <td></td> <td style="text-align: center;">1</td> </tr> <tr> <td></td> <td style="text-align: center;">2</td> <td style="text-align: center;">3</td> <td style="text-align: center;">4</td> <td style="text-align: center;">5</td> <td style="text-align: center;">6</td> <td style="text-align: center;">7</td> </tr> <tr> <td></td> <td style="text-align: center;">8</td> <td style="text-align: center;">9</td> <td style="text-align: center;">10</td> <td style="text-align: center;">11</td> <td style="text-align: center;">12</td> <td style="text-align: center;">13</td> </tr> <tr> <td></td> <td style="text-align: center;">14</td> <td style="text-align: center;">15</td> <td style="text-align: center;">16</td> <td style="text-align: center;">17</td> <td style="text-align: center;">18</td> <td style="text-align: center;">19</td> </tr> <tr> <td></td> <td style="text-align: center;">20</td> <td style="text-align: center;">21</td> <td style="text-align: center;">22</td> <td style="text-align: center;">23</td> <td style="text-align: center;">24</td> <td style="text-align: center;">25</td> </tr> <tr> <td></td> <td style="text-align: center;">26</td> <td style="text-align: center;">27</td> <td style="text-align: center;">28</td> <td style="text-align: center;">29</td> <td></td> <td></td> </tr> <tr> <td></td> <td></td> <td></td> <td></td> <td></td> <td></td> <td style="text-align: center;">30</td> </tr> </table>	S	M	T	W	T	F	S							1		2	3	4	5	6	7		8	9	10	11	12	13		14	15	16	17	18	19		20	21	22	23	24	25		26	27	28	29									30
S	M	T	W	T	F	S																																																						
						1																																																						
	2	3	4	5	6	7																																																						
	8	9	10	11	12	13																																																						
	14	15	16	17	18	19																																																						
	20	21	22	23	24	25																																																						
	26	27	28	29																																																								
						30																																																						



### **Bowling - Gene Arend**

Dear Bowlers: Welcome back to Friday Bowling season 2014-2015. We will begin bowling on October 17th. Arrive at Countryside Lanes around Noon and we start practice at 12:20. The cost this year will be \$10.00 per week. Bob Barr will provide additional information on fees for the season. We could use your recruiting skills; have friends call me. Those who have indicated your desire to bowl this season, we look forward to your joining us. If conditions have changed and you cannot bowl this season, please contact Gene Arend immediately. The team line up should be posted on clubhouse boards and website [www.mybriarcreek.com](http://www.mybriarcreek.com) by 9/20. Last minute changes could impact the line up so final team line ups will be posted by 10/2. Roster will be presented to the bowling house 10/3.

Gene Arend, Secretary  
727-725-5844 or  
[gnparend@tampabay.rr.com](mailto:gnparend@tampabay.rr.com)



### **Thought for the Month**

"The best and most beautiful things in the world cannot be seen, nor touched... but are felt by the heart". – Helen Keller

### **Message from your Editor - Betty Chatigny**

The kindness and caring thoughts from Briar Creek friends following the recent death of my daughter, Leslie Ingersoll-Lasko, warmed my heart. Even though my daughter had been ill for many years, her death during my last visit was unexpected. My heartfelt thanks to all those who expressed sympathy. Leslie's funeral was held in my hometown cemetery and, being a 14-year veteran of the U.S. Marines Corps, she was given a traditional farewell with military honors, including a fly-over from the Third Battalion, 25th Marines, Lima Company, Columbus, Ohio.



# Barron's

☎ 784-1603

## Air Conditioning & Heating, Inc.



• License #RA0058337 • Insured • Bonded



**Goodman**

Air Conditioning & Heating

*"Service is Our Specialty"*

We Service  
All Makes & Models

NOW CLEANING &  
SANITIZING DUCTS



28 ★ New Installations 28

## MOBILE HOME DEPOT

YOUR MOBILE HOME PARTS WAREHOUSE!

• Mobile Home Supplies • RV Accessories • Aluminum Products

22 ★ **Do It Yourself & Save!** 9

• Largo - 13777 66th Street North • **535-1100**

• New Port Richey - 7118 U.S. Hwy. 19 • **849-4900**

Store Hours: M - F 8-5 • Sat. 8-12  
www.mobilehomedepot.net



## CARPET DRY CLEANING

DRIES IN MINUTES - NOT HOURS

Living Rm, Dining  
Rm. & Hall **\$65**  
Includes...**FREE**  
Deodorizer & Spotting Kit

SAFE FOR MOBILE  
HOME FLOORS

- DRAPERIES
- Tile & Grout
- Furniture
- RV • Auto

11 ★ • Truck Mount Steam Available • Insured 4

**BILL The CARPET GUY 727-521-4163**

## KITCHEN & BATH REMODELING

THE HOUSE DOCTOR DOES IT ALL

Over 37 Years Experience

38 ★ **FREE ESTIMATE NO-OBLIGATION** 25  
• Ask the Better Business Bureau • License #C8623



**258-9101**

FLORIDA CONSTRUCTION CO.



Jean  
Satterfield

# AVON

- 16 Years Representing Avon
- Top Seller In Pinellas County
- Delivery to Your Home

To Receive a Brochure call:

**727-724-6450**

★ [ur4avon@tampabay.rr.com](mailto:ur4avon@tampabay.rr.com)  
[www.youravon.com/jsatterfield](http://www.youravon.com/jsatterfield)

# MAJOR APPLIANCE REPAIR SPECIALIST

**FREE Service Call**  
with Repair

- Refrigerators
- Microwaves
- Ranges
- Freezers
- Cooktops
- Disposals
- Wine Coolers • Dishwashers • Wall Ovens
- Washer/Dryers • Icemakers



- GE • Sears
- Whirlpool
- Frigidaire
- & Many others

**10% DISCOUNT**  
with repair - with this ad



**Appliance Specialty, Inc.**

**727-520-6002 • 727-441-2716**

6 ★ • Licensed & Insured • 37+ Years Exp. 1

# MOBILE HOME WASHING

**Protect Your Health!**  
**Eliminates Mold & Mildew**

**\$69<sup>00</sup>** Awnings, Carports  
& Screen Rooms  
Included  
**ANY SIZE**

Cleaning also available for...  
• Driveways • Patios • Walks

**Ron Wyngarden** INSURED

22



**587-0876**

22

# The Medicine Shoppe

*Come in and See Why So Many Customers that Shop at the Big Chains  
are Switching to the Medicine Shoppe Pharmacy of Dunedin*

**WE ACCEPT MOST INSURANCE PLANS!**  
**BETTER PRICES • BETTER SERVICE • BETTER FEELING**

**FREE DELIVERY**

**727-733-0404**

938 Patricia Avenue • Dunedin

**www.medicineshoppe.com**

**Open:**

Mon. - Fri.,  
9:00 - 6:00,  
Sat. 9:00 - 3:00

14 ★ 12

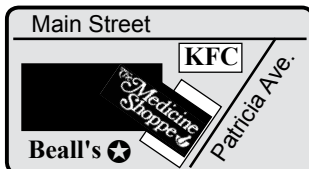

The Medicine Shoppe

**NEW CUSTOMERS**

**Fill 3 or More  
Prescriptions  
And Get A...**

**\$25<sup>00</sup>**

**GIFT  
CERTIFICATE**

Gift Certificates may be used on second visit to pay for any purchase. Must present this coupon to receive gift certificate. Not valid with any other offers. Limit one coupon per customer per year. Expires 9/30/14

The Medicine Shoppe

**NEW CUSTOMERS**

**Fill 2 or Less  
Prescriptions  
And Get A...**

**\$15<sup>00</sup>**

**GIFT  
CERTIFICATE**

Gift Certificates may be used on second visit to pay for any purchase. Must present this coupon to receive gift certificate. Not valid with any other offers. Limit one coupon per customer per year. Expires 9/30/14



## Briar Creek Bugle Phase II – October 2014

(Pete Loranger-Editor Phone 421-2321)

(E-Mail: Pete316@Knology.net)



### **S**unday Breakfast **Chefs, Dumb, Dumber, Dumbest and Dummy**

You are invited to breakfast on October 26, 2014.

Chefs Dumb, Dumber, Dumbest and Dummy will be serving

eggs, hash brown patty, sausage gravy and biscuit, along with the usual Danish, fresh fruit, orange juice, coffee or tea. Tickets will be on sale at Saturday morning coffee, from October 4 - 22; or you can buy them from Bob Bowlby 727-724-9406. Cost is \$3.00.

### **Ladies' Luncheon - Hildie Meyer**

The Ladies' Luncheon this month will meet on October 15th, 1 p.m., at the Outback Steakhouse. They have told me that they would make an extra effort in the seating arrangement for us to be all in one location, and will call me to confirm. The person I spoke with informed me that they were not accustomed to parties of our size; so, let's see what they come up with. Address is 31988 US Hwy 19, Palm Harbor (between Curlew and Tampa roads). Hope to see you there.

### **Briarettes' - Carol Smitley**

I hope all of you had a wonderful HOT summer. I am so ready to get back to our fall and winter schedule. I hope everyone else feels the same way.

The speaker for the October 7th meeting will be Nita Fields, Independent Designer of lockets. Every locket tells a story. You can put items in the locket that means something to you. Something that is important to you, something that will keep your loved ones close. I hear that she has a great fall collection. If you recall she was scheduled for April but had a death in the family and had to cancel.

We will have dessert and coffee. November we will have the popular dump salad.

Our meeting starts at 1:00. Again, that is October 7th. Mark it on your calendar.

Carol Smitley, President





## **Entertainment - Marge Grohskopf**

Oct. 18th will be the Oktoberfest. The Berglings and Bowlbys will be in charge of the cooking. We would like 3 volunteers to assist with the set-up.

Tickets will go on sale Sept 20- Oct.11 \$10.00 per person. A German Dinner of Brats, Potato Salad, Green Beans, Sauerkraut, Bread, Butter and German Apple Cake. Entertainment by the Deutschmeister Blas Band. BYOB at 5:30, Dinner at 6:30 and Entertainment 7-9:00. Please bring your own silverware. Tickets available at Coffee Hour or call Marge 474-7842.

Bunco will be on Thurs. Oct.23, Tickets are on sale now. 6:30 Dessert 7:00 we begin Bunco. Bunco is an easy game, a good way to meet people and get out of the house. Tickets are \$3.00 which goes toward prize money.

Fri. Oct. 31st is "Trick or Treat" with a Pot Luck Dinner to follow. Trick or Treaters will be coming to your home between 4:15- 5:00 They will give you Candy and in return you give them something for the Food Pantry. At 5:00 we have a Pot Luck Dinner everyone is welcome to participate. Bring your dish and "Come on Down". We have had very successful food drives in the past, helping the families of Safety Harbor. Let's do it again! Get your contribution ready for the Trick or Treaters.

For those who wish to costume and collect the food, Please meet at the Clubhouse at 4:00. We need three volunteers to be at the Clubhouse as people arrive with their dishes.

Don't forget to check the media for Breakfast and Mingle information.

## **PROPOSED EVENTS 2014-2015**

COMMITTEE : Robin Feeley, Nancy Fogarty, Brenda Greene,  
Marge Grohskopf and Blake Starratt

- Oct. 18, 2014 Oktoberfest
- Oct. 23, 2014 Bunco
- Oct. 31, 2014 Trick or Treat Pot Luck Dinner
- Nov. 5, 2014 Let's Make a Deal Dinner
- Dec. 7, 2014 Golf Cart Parade
- Jan. 1, 2015 New Years Day Dinner
- Jan. 11, 2015 Showtime The Link Union
- Jan. 22, 2015 Bunco
- Jan. 31, 2015 Soup-a-Thon
- Feb. 22, 2015 Showtime Donna and Dunning
- Feb. 26, 2015 Bunco
- Mar. 8, 2015 Kitchen Party
- Mar. 21, 2015 Horse Races
- Mar. 26, 2015 Bunco
- May 9, 2015 Mother's Day Dinner

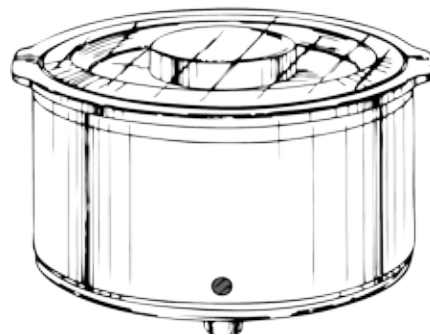



# Dental Walk-In Clinic

Learn More About Beautiful  
and Affordable Dentures

Full Service Dentistry

Relax With  
IV Sedation

**Open 7 Days A Week, With Extended Flexible Hours Including Holidays.**

Our Team's goal is to treat each customer as an individual, while providing superb clinical treatment, compassionate care and being available when you need a dentist.



**Two  
Locations**

State-of-the-Art Dental Implant Solutions Available

**FREE Limited Exam  
& Digital X-Ray**  
**\$85<sup>00</sup> Value**

Coupon must be presented at time of service. Not valid with any insurance, other offers or prior service. Valid one time for new patients only. ADA Codes 140,220 - Exp. 10/31/14

**FREE DENTURE & IMPLANT  
CONSULTATION** Learn more  
about affordable Dental Implant  
Solutions. Includes Limited Examination ADA  
Code 140. \$60.00 Value & Digital Panoramic X-Ray  
ADA Code 330. \$75.00 Value

Coupon must be presented at time of service. Not valid with any insurance, other offers or prior service. - Exp. 10/31/14

**\$100 OFF**  
**Your Next Partial  
or Complete Denture**

Coupon must be presented at time of service. Not valid with any insurance, other offers or prior service. Only valid for one complete or partial denture. Valid for ADA Codes 5110,5120,5213,5214. Not valid on ADA Codes 5130,5140,5211,5212 - Exp. 10/31/14

Specials are valid at  
Pinellas locations only.



**727-533-9199** 1030 Belcher Road S. • LARGO

Tampa Location • 813-636-9400 • 4240 W. Kennedy Blvd.

Mark R. Holmes, DMD  
Lic. # DN15675

8



[www.dentalwalkin.com](http://www.dentalwalkin.com)

7

\*Fee may vary with complexity of case. If any service, examination or treatment is performed within 72 hours & is a direct consequence of the original advertised full-fee or discounted service, examination or treatment, a patient or any other person financially responsible has the right to refuse, cancel, or be reimbursed for payment of the resulting procedure. Offers may not be combined.

*Swailles*

## Kitchen Re-Facing

**50%  
OFF**

with  
this ad

**Don't  
Replace It...  
RE-FACE  
IT!**

**NEW DOORS  
& MATCHING  
LAMINATE**

Gary Swailles  
Contractor  
Lic. #10585

**727-804-1689**

3



[www.swaillesrefaceit.com](http://www.swaillesrefaceit.com)

1

## FLOOR REPAIR

### MOBILE HOME SPECIALIST

- Any kind of damage to any kind of floor system.
- Small areas or whole homes.
- Replacement or deckover.

Ask About Our  
Other Services

**OWNER OPERATOR  
NO SUB-CONTRACTORS**

**Perfect Repair & Construction, Inc.**

**22** ★ State Certified Building Contractor **18**

**FREE ESTIMATES • 539-0852**

Licensed and Insured • State License # CBC050061

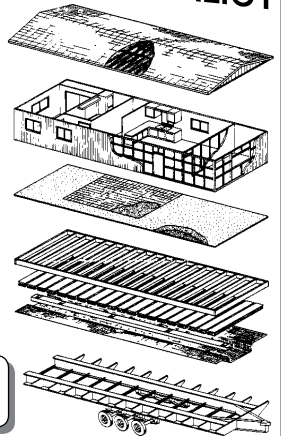

# PLUMBING SERVICES



Specializing in  
Mobile Home  
Repipes & Repair

**\$10 OFF**  
1st Time Customers

Did You Know We Service  
and/or Install Top Quality?

- Disposals • Stoppages
- Bathroom & Kitchen Fixtures
- Water Heaters • Water Softeners
- Reverse Osmosis Filter Systems



Call Us for All Your Plumbing Needs!  
[www.the-plumbing-patrol.com](http://www.the-plumbing-patrol.com)

**726-9193 or 942-9317**



## SUPERIOR Vapor Barrier

**What Does Your Vapor Barrier Look Like?**

**Do You Have Falling Insulation...Holes in Your Vapor Barrier?**

**INSIST ON 8'  
VAPOR  
BARRIER**

Repairing these issues helps prevent:

- Heat & Humidity Damage
- Soft & Sagging Floors
- High Energy Usage
- Rodent & Insect Damage
- Dangerous Mold and Fungus

**FREE  
PHOTOS**  
on Request



**ASK FOR A FREE INSPECTION  
OR SECOND OPINION FROM  
SOMEONE WITH EXPERIENCE!**

**WE CAN EASILY REPAIR THESE ISSUES.**

**GUARANTEED AS LONG  
AS YOU OWN THE HOME!**

**ASK  
ABOUT OUR  
DISCOUNTS!**

**727-470-0040**

*Not Associated with  
Superior Heating & Air*



• License #IH1054397 • Bonded • Insured **2**



## **Travel Club - Billie Ann Berry**

### **Some of our trips coming up this Fall are:**

- October 10 & 11 will be Fort Myers Discovery, \$209pp or \$241 single (2days/1 night). Visits to Fishermen's Village, Miromar Outlets and Mystery Dinner Train, including dinner aboard.
- November 22 we will cruise from Tampa aboard "RCCL" Brilliance of the Seas for 6 days/ 5 nights to Key West ad Cozumel starting at \$519.
- November 27 will be the Thanksgiving Day Buffet Cruise aboard Starlight Majesty Dining Yacht out of Clearwater for \$59pp.
- December 6, Bok Tower Gardens, \$79pp. Includes transportation, admission to Bok Tower Gardens, Pinewood Estate Tour, Sunset & Symphony Holiday Concert and a box lunch.
- December 22, cruise on Carnival for 5 nights to Nassau & Little Stirrup Cay. Inside cabin \$659 and Outside cabin from \$759.
- March 22- 28, 2015 will be the trip to Tunica and Memphis (7 days/ 6 nights) for \$477pp or \$672 single. Includes transportation, 6 nights lodging including 4 consecutive nights at a Tunica area Casino Resort. 10 meals: 6 breakfasts and 4 dinners, admission to Graceland - Home of Elvis Presley, admission to Tunica Museum, free time on Beale Street in Memphis, plus guided tour of Memphis and so much more.



Any questions, please contact Billie Ann Berry at 727-797-3116.

## **Monthly Mingle - Jean Williams**

Your Monthly Mingle for October will be held on Thursday Oct. 16th from 4:30-6. We look forward to seeing everyone including our returning residents. It is a great time to CHAT AND MINGLE and share our stories and travels etc.. from the summer..... If you haven't been able to make it before, stop by and say Hi. Bring a neighbor, a dish to share and your own beverage. And bring a dollar bill for our drawing.

We hope to see you on the 16th.

**WELCOME BACK TO ALL OUR SEASONAL RESIDENTS !!!!!!!**

## **Notice from the Condo Board**

We are missing two wheelchairs from the closet in the Exercise Room. Please let us know if you are using either one and when you will be finished needing them. We have others in need and would like to help them. Thank you for your cooperation.

**ALSO – Condo Board Meeting will be held on 10/21 at 7pm.**



## Shuffleboard - Tom Feeley

Your shuffleboard team needs players for the upcoming 2014-2015 season. League play will start on a date to be determined in November. There is a sign-up sheet located in the clubhouse and also at the shuffleboard court. Practice is on Tuesdays, 1 to 3 PM with league games played on Wednesday from 12 to 4 PM, at our home courts or within three miles from Briar Creek. The West Coast District schedule is also located in the clubhouse with tournaments starting on October 2, 2014 for both beginners & advanced players. Anyone interested in joining please sign up or call Tom Feeley if you have any questions.

## MEMORIAM

Juanda Hasty - 9/7/2014

## Birthdays and Anniversaries - Pete Loranger

### Birthdays

10/01	Mike Lucas	10/19	Cindy Perry
10/02	Judy Cochrane	10/20	Marilyn Whitelaw
10/02	Arlene Rosenberg	10/22	Janie Dennis
10/03	Louise Anderson	10/23	Nancy Burch
10/05	Gene Stowe	10/24	Darlene Beyer
10/05	Yaeko Parish	10/24	Sandy Fassett
10/07	Stewart Jones	10/24	Lyn Hoage
10/08	Charles Seideneck	10/24	Rosie Namadan
10/10	Angelo Farese	10/24	Jean Martin
10/11	Judy Meek	10/25	Ramona Hatch
1011	Marie Farese	10/25	Art Tavenor
1011	Sandy Watson	10/26	Peggy Raynor
10/12	Jim Smart	10/26	Rick Dimock
10/13	Tim Riley	10/28	Ed Snell
10/14	Kim Phillips	10/29	Lisa Guerino
10/16	Art Geders	10/29	Irena Malacky
10/17	Joseph Guerino	10/31	Sandra Barry
10/19	Terry Frasch	10/31	Carol Vecchio



*If any dates are incorrect, contact Pete. If dates are not listed, I have not received a Resident Info form. They are available on bulletin board at clubhouse.*

### Anniversaries

10/17/1965	Richard & Helen Ham – 49 years
10/19/2002	Bill & Darlene Beyer – 12 years
10/20/1956	Larry & June Van Wormer – 58 years
10/26/1963	Joseph & Helen Guerino – 51 years
10/31/1950	Ed & Audrey O'Connor – 64 years



# CARPET "DRY" CLEANING

## FURNITURE & LEATHER CLEANING

We have cleaned 1000's of Manufactured Homes in Pinellas County with incredible success!

We hope that our credentials & over 50 years as a family owned business allows you the confidence to select Doll Bros. for your cleaning needs.



Family Owned & Operated for 50 Years

**727-596-2249**  
[www.dollbros.com](http://www.dollbros.com)

# MASTER ELECTRICIAN

John Haseney 36 Years Pinellas County

**441-8434**



**10% DISCOUNT**  
1st Service Call



17



Haseney Electrical Services, Inc.  
 • License #EC 13001677

5

# GOLF CARTS

## CLEAN USED & NEW CARTS

• Buy • Sell • Trade • Repair • All Brands



Specializing in...



Sorry, we do not buy or sell E-Z-Go RXV due to very high cost of repair parts.



## WANTED DEAD OR ALIVE

Carts Any Condition • Highest Prices Paid

10 Year Proven Customer Satisfaction Record

Exclusive 100% / 6 Month Parts Warranty on Electrical Parts, Batteries, Controllers, F & R Switch & Solenoids on All Refurbished Used Carts  
 (7th thru 12th months - 50/50 parts warranty on all above)

All New Batteries Have an 18 Month Warranty

Pick Up & Delivery - \$25 Each Way (In Pinellas County)

Special DOT Rated Tire with Wheel



All Club Cars Have Lifetime Bumper-to-Bumper Main Aluminum Chassis Warranty (excluding battery cradle)

- Check Our Labor Rates Against the Competition
- 10 Years This Location • We Repair Chargers
- Charger Check-Up FREE at Our Store

RECREATIONAL GOLF CARS OF FLORIDA, INC.

**8801 66th Street North • Pinellas Park**  
 Open Mon.-Sat. • Sun. by appt. **548-8460**  
 (2.8 miles south of Ulmerton Rd.)

## 13 All Your HOUSE CLEANING Needs 13

**DOREEN'S CLEANING SERVICE** Single wide \$40.00  
 Double wide \$50.00  
**846-0533**



I'll also clean • Walls • Inside Cabinets & Porches

## BARBER SHOP

**Andrew Ciresi • Master Barber**  
 2340 State Road 580 • Columbia Plaza  
 (North of K-Mart Garden Center)

**All Cuts \$12 726-0094**

Style Cuts • Fades • Flat Top  
 Tues - Fri 8:30 - 5:00 • Sat 8:30 - 2:00

**\$10 SENIORS 65 & UP**

**TWO Barbers Now To Serve You**

Come and See Why We're the...  
**TALK OF THE TOWN**

# Vakesh Rajani, M.D.

**Board Certified Internal Medicine • Cleveland Clinic Trained**

Dr. Rajani completed his residency at The Cleveland Clinic Foundation in Ohio. He was chosen as Chief Resident and served on the academic staff at the Cleveland Clinic prior to starting his medical practice in Florida. Dr. Rajani has been practicing medicine in North Pinellas for over 15 years.



- Recipient of the Bernard A. Macik Jr. 'Excellence in Medicine' award at Morton Plant Mease Hospitals
- Founding Director of the Mease Hospitalist Programs at Mease Countryside & Mease Dunedin Hospitals
- Served as Vice Chair of the Department of Medicine at Mease Hospitals
- Contributing Author, 2nd and 3rd Editions of the Cleveland Clinic Intensive Review of Internal Medicine.

## Services Offered

- Primary Care and General Internal Medicine
- Hospital Visits / Inpatient Care
- In Office Blood Draws
- EKGs
- Coumadin Monitoring
- Joint Injections
- Well Woman Exams (Female Provider Available)
- Hypertension, Diabetes, COPD, Heart Disease and Osteoporosis Management



## Plans accepted include:

- **Humana Gold Plus**
- **Freedom**
- **Optimum**
- **Medicare**

## *Welcoming new patients at two office locations:*

Humana Gold Plus patients are seen at our Dunedin office

**2812 St. Marks Drive  
(Caladesi Publix Plaza)  
Dunedin, FL 34698**

**1840 Mease Drive, Ste 401B  
(Mease Countryside Campus)  
Safety Harbor, FL 34695**

# 727-328-4633

[www.rajanimed.com](http://www.rajanimed.com)





## MARK YOUR CALENDARS

**S**unday, November 30th is **Briar Creek's Hobby and Craft Show** at Phase 1's Clubhouse. Both Phases are invited to participate!

It's been many years since this event was held and there has been a lot of interest in having one, so here are the details:

Hours – 1PM – 4PM

Cost – If you just want to display or demonstrate your hobby or craft, your table is **FREE!** If you would like to also sell your hobby or craft, each table is a nominal \$10.00 which goes to the Social Club. Money is not due until November 1st.

You can have as many tables as you'd like.

Now is the time to show off all your hard work and talents and maybe make some money back on your investment of time and material! We have so-o-o many talented residents that have kept their talents to themselves. **NOW IS THE TIME TO SHARE!**

Contact Andy Philyaw 793-9819 with any questions or to reserve your tables for this wonderful upcoming combined Phases event. Reminders will be sent in both the October and November Monthly Medias and will be announced as a reminder by your Media Representative at both Phases Coffee Hours Periodically.

**It will be a BLAST!!**



**VINYL SIDING**  
Complete Mobile Home Service

by **Mitchell Siding** INCORPORATED

*"Workmanship  
Makes the Difference"*

**Top Quality Work At Low Prices**

• Licensed & Insured • Aluminum Contractor • PCCLB #C-7812



**586-6315**





# Ladies Golf at Briar Creek

Jane McKenzie

## Ladies Golf at Briar Creek (Phase I & II)

The ladies golf group has been growing this winter. We now have 6 to 9 players on a regular basis, and there are 18 signed up for next winter. If you have ever golfed and would like to try again, or if you are a regular golfer and want to join a casual group, please email me at [jgmckenzie4647@gmail.com](mailto:jgmckenzie4647@gmail.com).

We will continue to meet at Countryway Golf Course, but we have the option for different start times. Please let me know if you want to get the information for the 2014-15 winter, and I will forward you the details in early fall. This will not obligate you to attend, but will let us know how many are interested in getting the information and possibly playing next winter.

Thanks,

Jane McKenzie - 651-353-2602 (cell)



## Bingo - Pete

We have begun our 2014/15 program. BINGO is played on Monday evening and we start selling cards at 5:15 and play begins at 6pm. You can play every game for as little as \$5.00 for all 19 games. Of course there is no limit on the number of cards you may want to purchase and play!! COME ON DOWN!

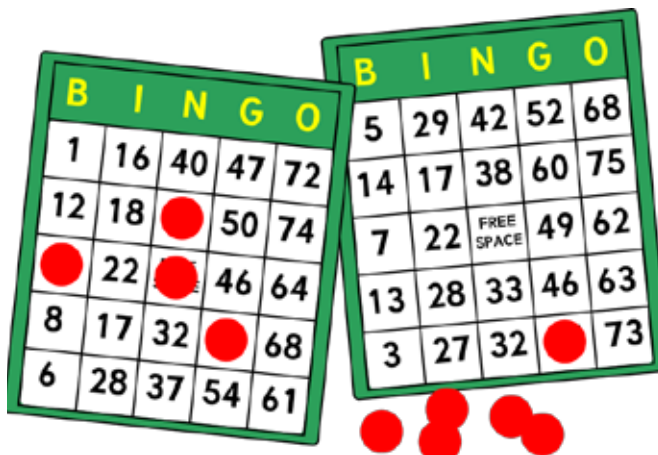



# EMPORIUM

**10 WORDS for \$8.55 – Each additional word is 80¢**  
**Your Ad Will Appear in 60 Mobile Home Park Newsletters**  
**NO ADS ACCEPTED BY PHONE OR EMAIL**

ARTICLES FOR SALE	WANTED TO BUY	EVENTS & PROGRAMS
<p>ANNUAL INDOOR YARD SALE                      Friday, October 17th 8AM-2PM                      Dunedin Clearwater Elks Lodge                      1240 San Christopher Drive, Dunedin                      Household Goods, Collectibles, Jewelry, Clothing Coffee/Donuts, Hot Dog Lunch, Bake Sale</p>	<p><b>When selling on consignment always get a WRITTEN QUOTE on the sellers' commission.</b></p>	<p>BINGO, Sugar Creek MHP, Every Thursday, sales close 6:30p. 10265 Ulmerton Road, Largo (Behind Peir One Store) opening October 9th Free coffee and donuts to start our new season. Hope you can join us.</p>
<p>Park-wide Sales, Oak Crest/Acorn MHP Arts&amp; Crafts/Holiday Gifts/Household Items Saturday, Nov 8, 2014 8am-4pm 9925 Ulmerton and 435 16th Ave SE (enter off Seminole)</p>	<p>!! TOP CASH PAID!! JEWELRY: GOLD, STERLING, COUSTUME (EVEN BROKEN JEWELRY), COINS, ANTIQUES, PAINTINGS, GLASSWARE, POTTERY, CHINA, ENTIRE ESTATES. FREE HOUSE CALLS, LAURA. ALL SALES SUBJECT TO APPROVAL. (727)422-0095</p>	<p>CRAFT FAIR - Sunday, Nov.9, 2014- 12pm to 4pm. Down Yonder Moblie Home Park- 7001 142nd Ave., Largo, 33771</p>
<p>3-Wheel Scooter, electric, brand new. Pride Mobility-Elite Traveler, battery charger.Black leather, red base, \$1200. Great price! 727-733-7780</p>	<p>GOT A CAR YOU WANNA SELL? THE GOOD, THE BAD, OR THE UGLY. CALL NOW: 727-400-1910.</p>	<p>Bay Ranch Annual Flea Market, Sat Nov 15, 2014 8-2 call 727-434-1065 7349 Ulmerton Rd, Clubhouse</p>
<p>Wheelchair-Medline transport, model MDS808150, light weight, folds, with foot rests. Barely used \$85.00</p>	<p>BUYING COIN COLLECTIONS. Proof and mint sets, old coins, currency, \$.03 for "Wheaties", American Flyer Trains. 688-9871</p>	<p>BINGO, Tuesday Nights, 6:30p.m., Paradise Island Clubhouse, 1001 Starkey Rd., Largo, 4 blocks south of East Bay. Kitchen open 4 to 6p.m. Dinner specials, sandwiches, Fries, desserts, ice cream, floats and sundaes. 29 games,\$50,\$250,\$250,\$250, payout-\$1850. Fun, Fun, Fun \$\$\$</p>
<p><b>HELP WANTED</b></p>	<p>CARS OR TRUCKS, Top dollar paid by Andrew 726-0094 or 785-1288</p>	<p>Christmas Craft Show: Saturday Nov. 15,2014, Paradise Island MHP 9-1. Over 60 crafters, canteen, raffles &amp; bake sale. Tables \$10 call Marcia 727-83-3616</p>
<p>Crafters Wanted at Ranchero Village Park off Ulmerton Rd Christmas Bazaar Nov.9th 12-3pm \$30.00 per table call Sandie 727-474-2446 leave a message</p>	<p>FURNITURE, good clean, pre-owned. Top dollar paid. Joe, 224-9780</p>	<p>Craft Fair, Saturday, October 11, 9am - 3pm., St. Paul United Methodist Church, 1199 Highland Avenue, Largo, FL 33770. Over 80 Vendors. Indoor &amp; Outdoor show. Great Food, Children's Activity Center. Handicapable Accessible. \$1.00 admission</p>
<p>CRAFTERS WANTED: Saturday, Oct. 25, 2014, 5pm-9pm First United Methodist Church Pinellas Park Annual Fall Festival. Tables \$5. Call (727)546-5741. Please leave a message</p>		
		

## NOVEMBER AD DEADLINE - OCTOBER 10, 2014

• Advertise BUY, SELL, TRADE ITEMS NOW by sending \$8.55 to Monthly Media at P.O. Box 1023, Venice, FL 34284.  
 • Ads over 10 words must be accompanied by \$.80 per extra word or publisher will edit. • No mobile home sales, professional products or services. SORRY: No ads accepted by phone or email. DEADLINE: 10th OF EACH MONTH.

# RAY DUNCAN PLUMBING, INC.



"SPECIALIZING IN MOBILE HOME REPAIRS"

- Sewer & Drain Cleaning • Washer & Dryer Hook-Ups
  - All Brands Faucets & Fixtures Repaired & Replaced
  - Water Heaters Repaired & Replaced
- 24 HOUR FAST & CLEAN SERVICE**

**733-0968**

620 UNION STREET • DUNEDIN

[www.rayduncanplumbinginc.com](http://www.rayduncanplumbinginc.com)

Over 30 Years Experience • Master Plumber • CFC1428802



28

35

**FAMILY OWNED & OPERATED**

## It Pays (Up to \$100.00) To Patronize The Advertisers In Your Newsletter EVERY TICKET is a WINNER! - 50¢ Goes to American Red Cross for Every Ticket

Not only will you be letting the advertisers know you appreciate their supporting your newsletter but you may also become eligible to win up to \$100 in cash prizes! **And Now Monthly Media will donate 50¢ for every ticket submitted for the Monthly Mania Contest to...**



**American Red Cross**

**Even if your contest ticket is not a winner for you... 50¢ will go to American Red Cross for your ticket and every ticket turned in. This Month \$80<sup>50</sup> Went to The American Red Cross Because of Your Tickets**

**14,492 manufactured home residents have won over 124,374** since our contest began. It's simple to play ... when you patronize a current advertiser, ask for a Monthly Mania ticket (or a reasonable facsimile) and fill it out completely. Put the ticket in our Monthly Mania drop box in your community. That's all you do. At the end of the month the Publishers will pick up the tickets and hold a drawing. If your ticket is drawn, we mail you a check. (Allow 4-6 weeks for mailing of check). **This month's cash winners are:**

James Wright ..... \$100 ..... Appliance Speciality  
 James Smith ..... \$10 ..... Haseney Electric  
 Paul Humphries ..... \$10 ..... Florida Anchor & Barrier  
 MaryAnn Seyler ..... \$10 ..... Bob's MH Washing  
 Gerald Russell ..... \$10 ..... Mitchell Siding  
 Margaret Hedgen ..... \$10 ..... Suncoast Auto & Tire  
 Carl Chamberlain ..... \$10 ..... Imperial Electric  
 Joyce Shumaker ..... \$10 ..... Buggin Out Termite  
 Annette Candiano ..... \$10 ..... Notebooks Plus, Inc  
 Joan Henderson ..... \$10 ..... Marti's Hair Salon  
 Randall Vance ..... \$10 ..... E & E Gliddon AC  
 Laddie Novotny ..... \$10 ..... Superior Vapor Barrier  
 Harry Swank ..... \$10 ..... ASC, Inc.  
 Jean Schroeder ..... \$10 ..... Largo Tech Services  
 David Neumore ..... \$5 ..... Mobile Home Depot  
 Tyler Hank ..... \$5 ..... Doll Brothers Carpet  
 Florence Ballard ..... \$5 ..... Knoblach Hearing Care  
 Eric Lynn ..... \$5 ..... Knoblach Hearing Care  
 Ron Wallace ..... \$5 ..... Affordable Floor Covering  
 Jo Waldron ..... \$5 ..... Sunset Appliance Service  
 Inga Wade ..... \$5 ..... Doreen Cleaning  
 Marilyn Sorrell ..... \$5 ..... Royal Enterprises

Ron Puidort ..... \$5 ..... Modern Air  
 George Mann ..... \$5 ..... Largo Radiator Service  
 Charmain Courtney ..... \$5 ..... Dr. Peter Madon  
 Robert Holden ..... \$5 ..... Socia's Painting  
 Jeff Sander ..... \$5 ..... Doreen's Cleaing  
 Elizabeth Daddio ..... \$5 ..... Air Masters  
 Thomas Baker ..... \$5 ..... Doll Brothers Carpet  
 Eleanor Trout ..... \$5 ..... Denny's Plumbing, Inc.  
 Mike Renner ..... \$5 ..... Dr. Peter Mason  
 Andrea Durkin ..... \$5 ..... AMS WC  
 Wendy Bombardier ..... \$5 ..... Century Awnings  
 Doris Krieger ..... \$5 ..... Century Awnings  
 Jolene Lease ..... \$5 ..... Debbie's Salon  
 Audrey Nower ..... \$5 ..... Bob's MH Washing  
 Jon Williams ..... \$5 ..... Royal Enterprise  
 Roxanne Fitzner ..... \$5 ..... Ron Wyngarden MH Washing  
 Carolyn Cornwall ..... \$5 ..... Heller's Mobile Home Washing  
 Carol Barton ..... \$5 ..... Heller's Mobile Home Washing  
 Georgia Vaughn ..... \$5 ..... Jones & Sons Plumbing  
 Joan Corrado ..... \$5 ..... Jones & Sons Plumbing  
 Ruth Ann Zandy ..... \$5 ..... Jones & Sons Plumbing

• Limit of one ticket per visit • Advertiser may have up to 4 winners per month • Advertiser must have bill paid current to qualify • No purchase necessary • Contest void where prohibited by law • Green tickets available at participating Monthly Media advertisers.



**Board of Directors Responsibilities ... Social Club Committee Chairpersons (continued)**

Bowling.....	Gene Arend (725-5844).....	Marge Grohskopf (474-7842)
Breakfast .....	Bob Tompas (791-1417) .....	Berglings (799-2904) or Bowlbys (724-9406) or Bob Brown (1-419-345-2653)
Breakfast Tickets.....	Nancy Ellis (796-8528) .....	
Briar Creek Luncheon.....	Joan Bienvenue (724-8561)	
Backup.....	Lesley Zuckerman (712-8378)	
Briarettes, President .....		Carol Smitley (725-3948)
Bridge.....	Barbara Glasheen (712-9467)	
Coffee Hour .....	John Renken (813-408-6849)	
Coffee Preparation.....	Bob Barr, Wednesday Social (644-8136).....	Pete Loranger (421-2321)
Crafts .....		Darlene Beyer & Sandy Fasset
Decorations .....	Madelyn Geigenmiller (723-7046).....	Nancy Fogarty (459-2740)
Directory* .....	Joan O'Dell (796-4076).....	Judy Meek (712-2526)
Entertainment .....	Mary Kay McBride (791-3889).....	Marge Grohskopf (474-7842)
Exercises .....		
Food Bank .....	Joe Guazzerotti & Bill Sullivan .....	Joan Davis (726-4829)
Historian .....		TBA
Kitchen .....	Committee.....	Pete Loranger (421-2321)
Kitchen Supplies .....	Helen Coar (796-3923).....	Pete Loranger (421-2321)
Ladies Luncheon.....		Hildegard Meyer (793-9352)
Librarian .....	Lee Cameron (726-2323) .....	Jackie Labounty (797-0581)
.....		Pat Kleen (712-9180)
.....		Audrey O'Connor (723-2148)
Line Dancing.....		
Membership .....	Pauline Hoad (723-9710) .....	Jean Williams (712-8389)
Summer Membership .....	Pat Bourdon (797-3252)	
Monthly Media .....	Betty Chatigny (216-3871).....	Editor: Pete Loranger (421-2321)
Name Badges.....	DeWayne Hehl (724-1867) .....	Sharon Cann (366-7688))
Pool Tags* .....	DeWayne Hehl (724-1867) .....	N/A
Shuffleboard .....	John Wilson (791-8970) .....	Pres. Bill Beyer (725-0644) Captain Tom Feeley (796-5879)
Store.....	David Doran (585-329-3827)	
.....	Jeff Clark (585-329-3827)	
Sunshine .....	Joan O'Dell (796-4076).....	Jean Williams (712-8389)
Backup .....	Dot Sullivan (726-6084) .....	
Tables/Chairs.....	Dudley Geigenmiller (723-7046) .....	Pete Loranger (421-2321)
Tickets .....	Kathleen Cory (452-1607) .....	Marge Grohskopf (474-7842)
Travel Club .....	Judy Young (725-2090).....	Billie Ann Berry (797-3116)
BC Auto Stickers* .....		Jackie Labounty
Welcome Committee .....	Nancy Ellis (796-8528) .....	Jackie Labounty, Audrey O'Connor, Lyn Hoage

**Area Representatives**

Joe Guazzerotti.....	(725-0746)
Sharon Philyaw .....	(793-9819)
Shirley Payne .....	(725-4009)
Kathleen Cory .....	(452-1607)
Joe Casola .....	(723-0414)
John Gaglione .....	(781-6962)

**Area Representatives**

Kim Phillips .....	(723-7991)
Dottie Frederich .....	(725-4221)
Lyn & Ed Hoage .....	(669-5859)
June VanWormer.....	(726-0130)
Joan Davis.....	(726-4829)
Earl Bowermaster.....	(726-3472)
Arlene Lambert.....	(724-6482)

BC I • Editor: Betty Chatigny • 216-3871  
BC II • Editor: Pete Loranger • 421-2321

BC I • Editor: Betty Chatigny • 216-3871  
BC II • Editor: Pete Loranger • 421-2321

35

Certified years in business



No complaints unresolved

35

Years in Monthly Media

# MOBILE HOME WASHING

## Hand Washing Since 1988

### Single or Double Wide

# \$79<sup>00</sup>

## 545-2665

LICENSED & INSURED

Triple Wide or Special Additions May be Extra  
Screen Removal Not Necessary

### Heller's Mobile Home Washing

25 ★ ASK ABOUT OUR OTHER SERVICES 23

## ROOF WASHING & MINOR REPAIRS

### FREE Roof Inspection with washing 25 ★ 23

### Heller's Mobile Home Washing 545-2665



## FLORIDA Under Home SOLUTIONS

where budgets and home solutions meet

## AFFORDABLE VAPOR BARRIER

### Have You Looked UNDER Your Home Lately? **PROTECT YOUR HOME**

### Fix Small Problems Today Before They Cause Serious Damage!

We will inspect and photograph any issues, showing you pictures of the underside of your home. Damaged & worn vapor barriers can create high energy costs and allow mold & mildew to grow and weaken your sub floor creating "Soft Spots". Keep Mold, Moisture & Animals out of your Home.



Repairs will be made quickly and include a 20 Year Transferable Warranty!



Call Us for a FREE NO-PRESSURE No-Obligation Estimate

10% MILITARY DISCOUNT

4



## 727-492-1884

Licensed #OCL0027169  
Bonded • Insured

info@FloridaUnderHomeSolutions.com



# Summer is Here!

## Ask About Our SUMMER SPECIALS!

## E&E GLIDDON

LIC # CACO 24340

### Comfortmaker

Air Conditioning & Heating

FREE ESTIMATES on NEW UNITS

www.eegliddonac.com

24 Hour Service Service All Units



## 546-4343 • 527-1357



31 ★ 31

## AIR CONDITIONING

### NOW OFFERING DUCT CLEANING & SANITIZING

## \$45<sup>00</sup> A/C INSPECTION or Service Calls

(Mon.-Fri. 8AM - 4:30PM)